

Formation à la CAO

Exercices de modélisation

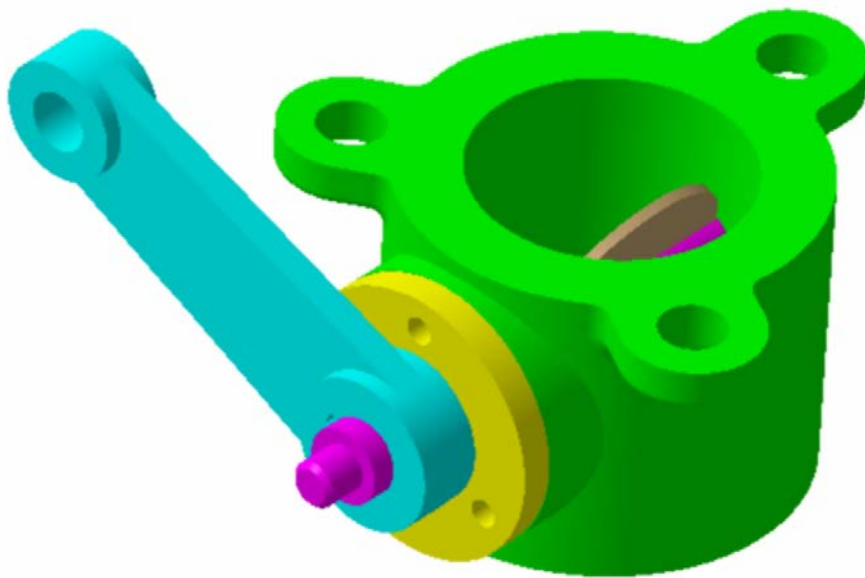

Pascal Morenton

pascal.morenton@ecp.fr

<http://cao.etudes.ecp.fr>

4

m

c

D

4

3

2

1

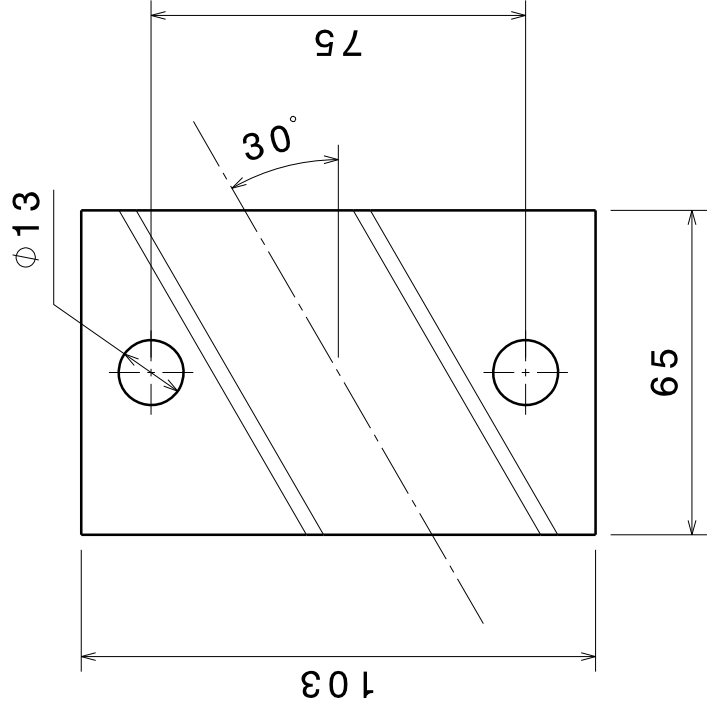
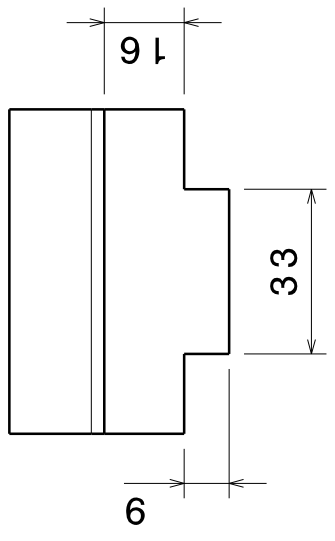
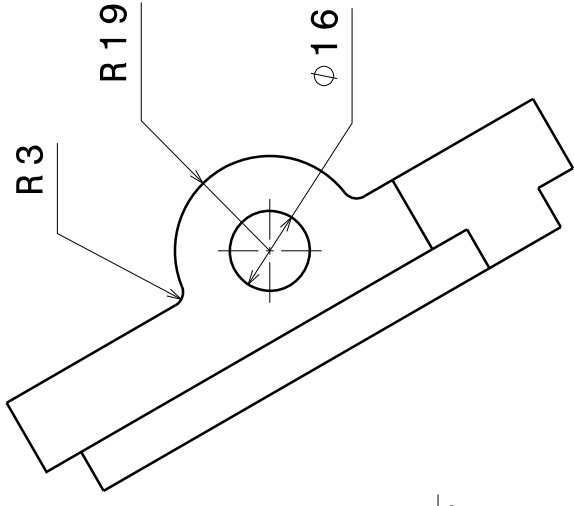
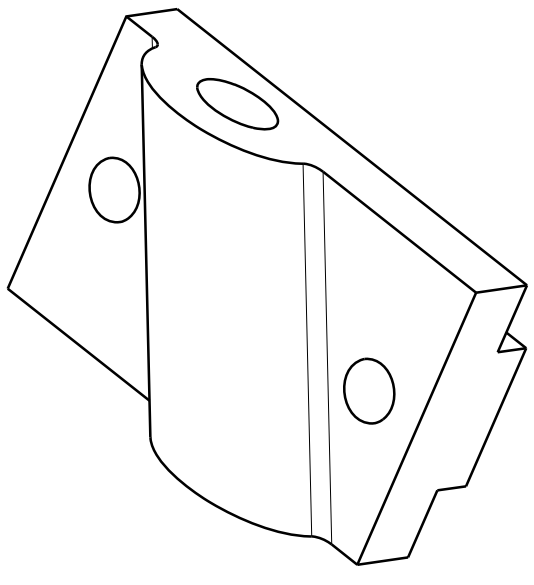

Projet

Formation CAO

Dessiné par

P. Morenton

Format

A4

Date

2:3 02/09/08

Revision

1.0

Piece 01

Ecole Centrale Paris

A

D

4

3

2

1

A

m

o

D

4

3

2

1

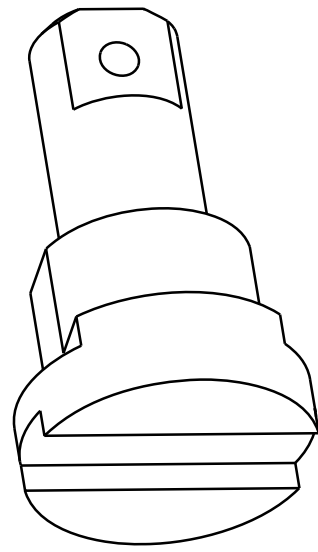
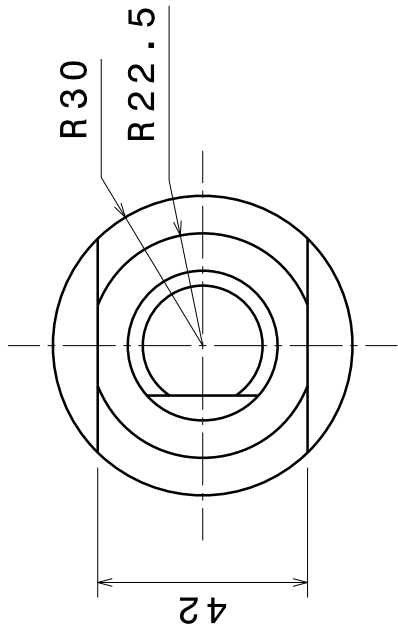
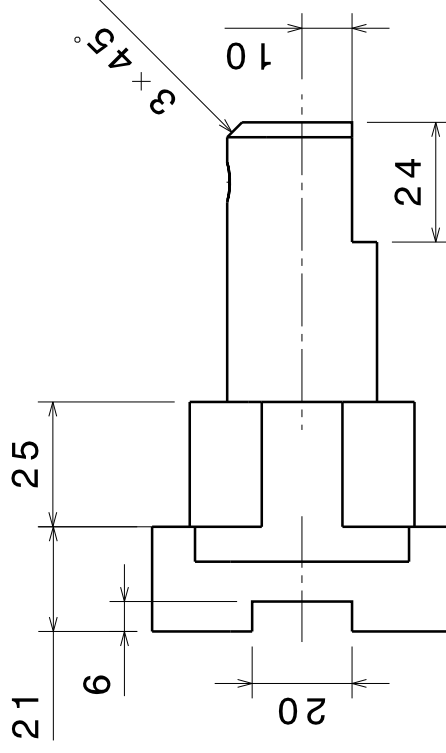
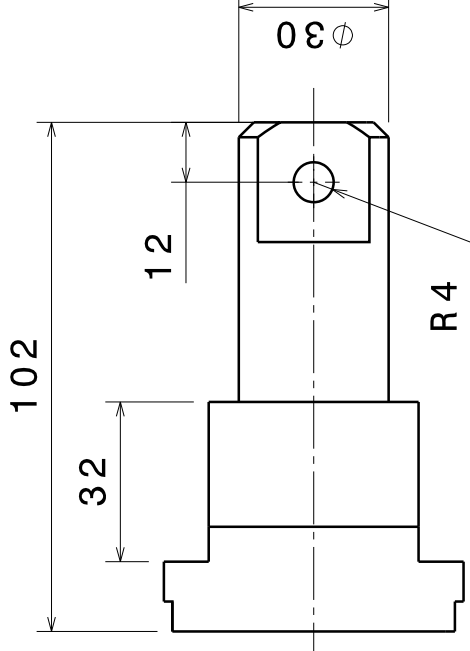

Projet

Formation CAO

Dessiné par

P. Morenton

Format

A4

Date

2:3

Revision

02/09/08

Revision

1.0

PIECE 02

Ecole Centrale Paris

A

D

4

3

2

1

4

m

c

d

4

3

3

2

2

1

1

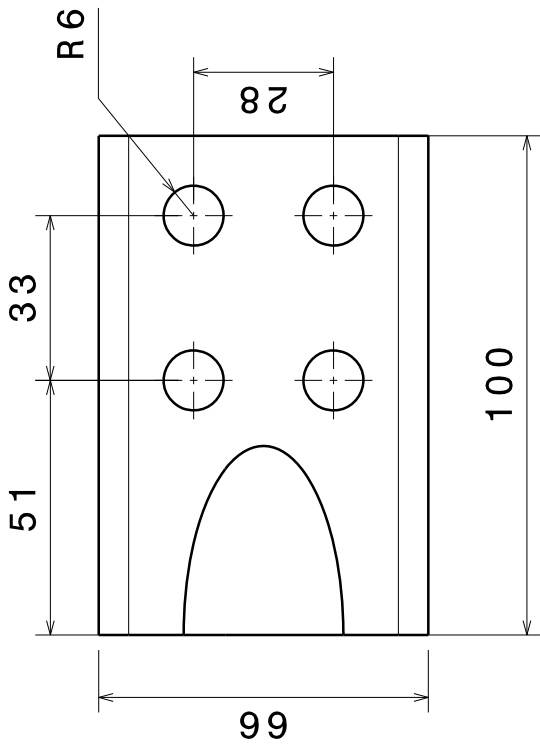
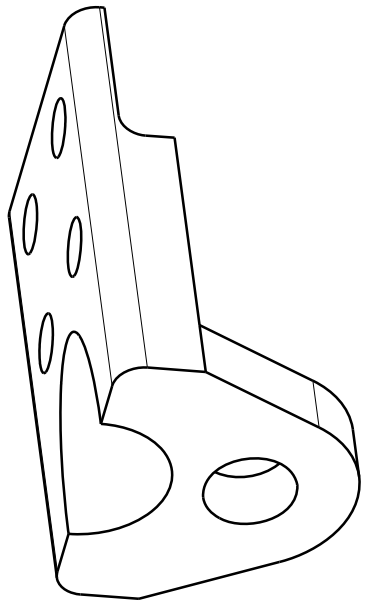
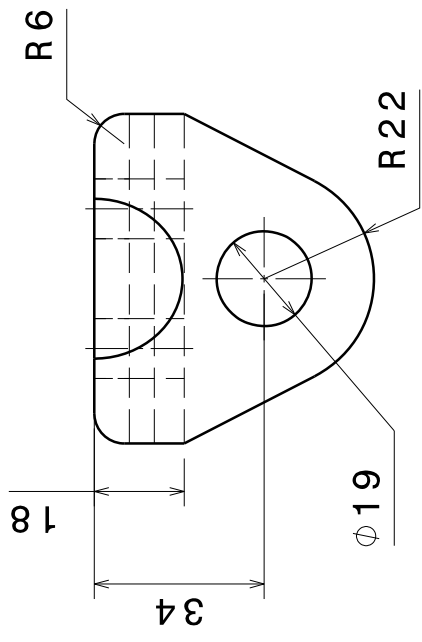
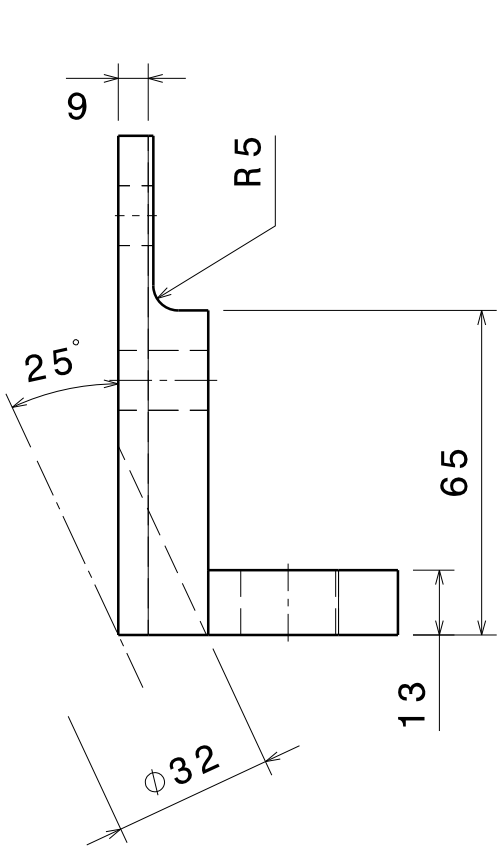

Projet

Formation CAO

Dessiné par

Format

Echelle

Date

Revision

P. Morenton A4 2:3

02/09/08

1.0

Piece 03

Ecole Centrale Paris

D

A

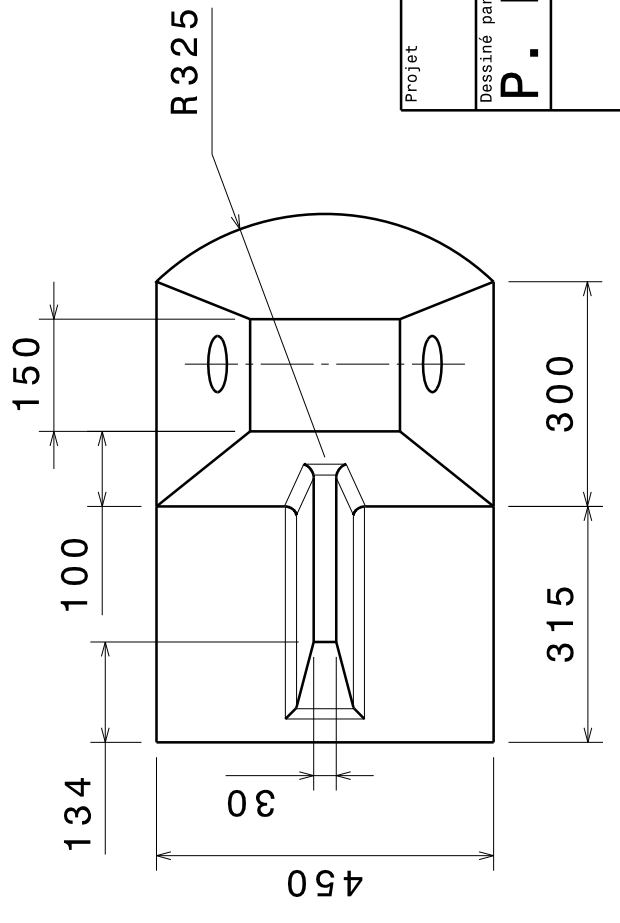
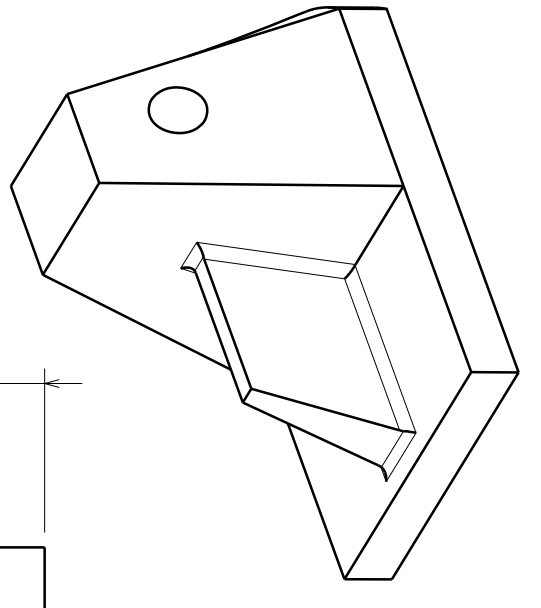
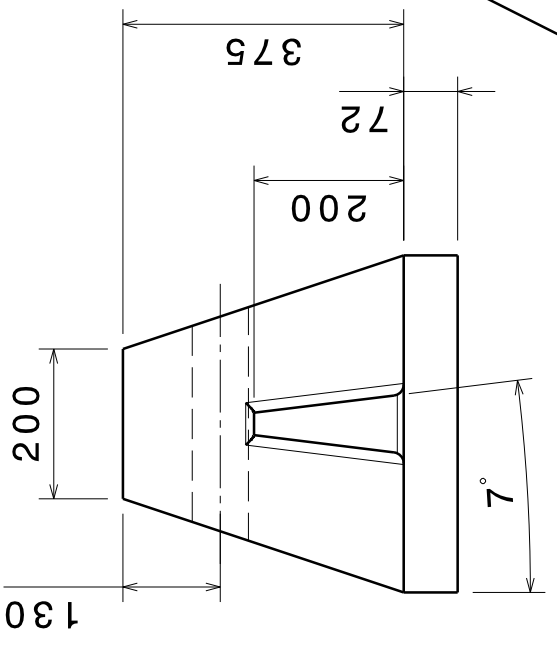
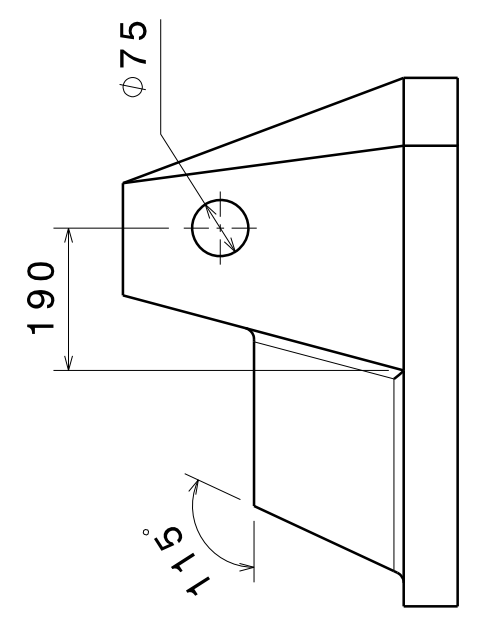

Projet

Formation CAO

Dessiné par
P. Morenton

Format
A4

Date

1:10 02/09/08

Revision

1.0

Piece 04

Ecole Centrale Paris

A

m

C

D

4

3

2

1

4

3

2

1

D

A

4 3 2 1 A D

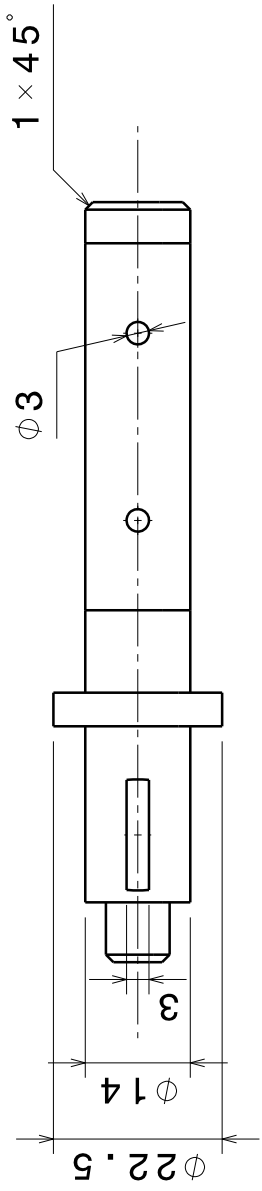
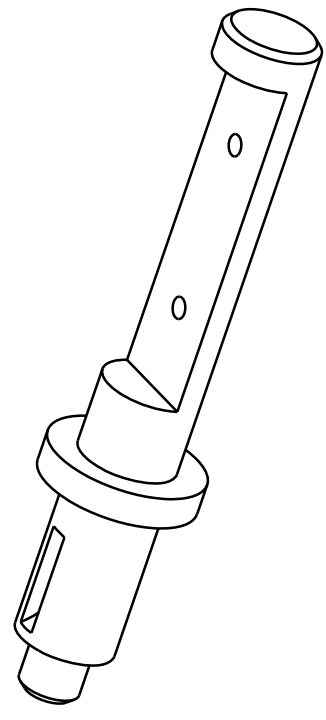
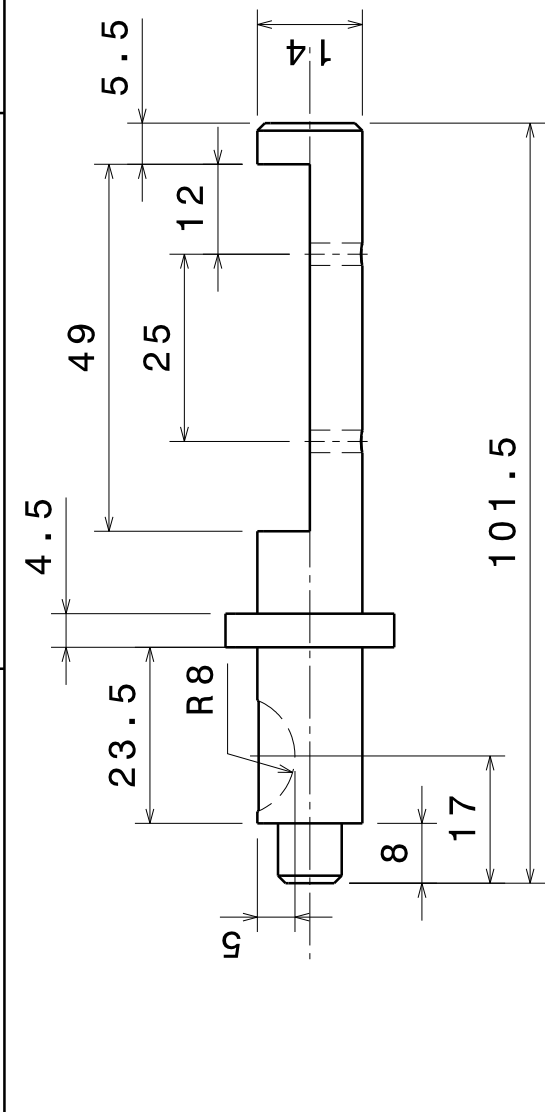

Projet

Vanne manuelle

Dessiné par	Format	Date	Revision
P. Morenton	A4	1:1 04/09/08	1.0

AXE

Ecole Centrale Paris

A

D

4

3

2

1

A

B

C

D

4

3

2

1

D

A

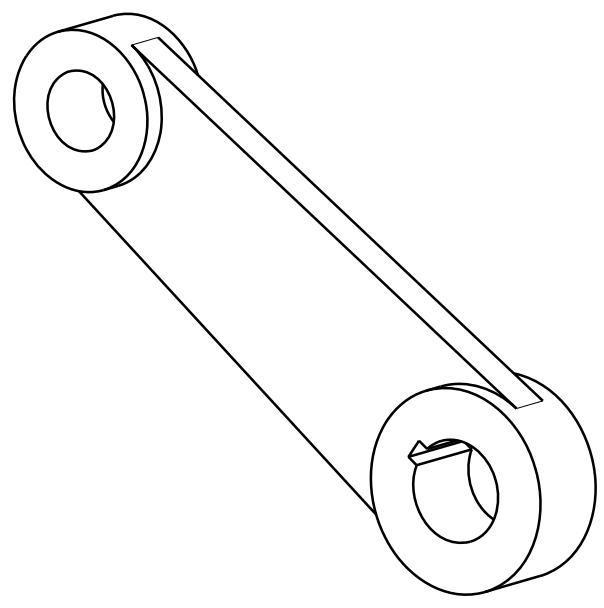
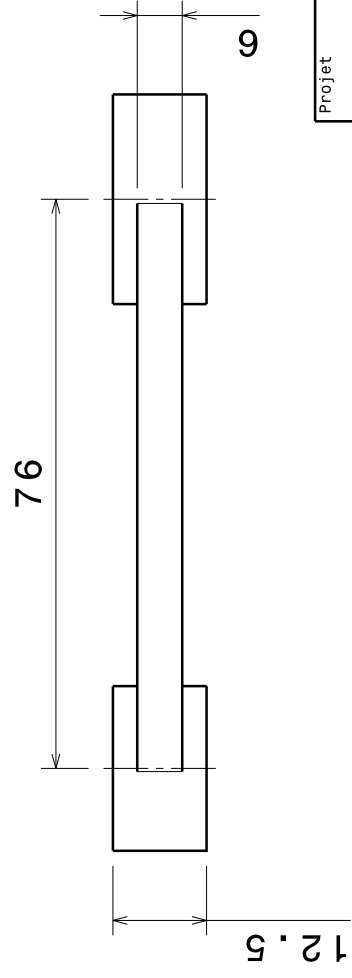
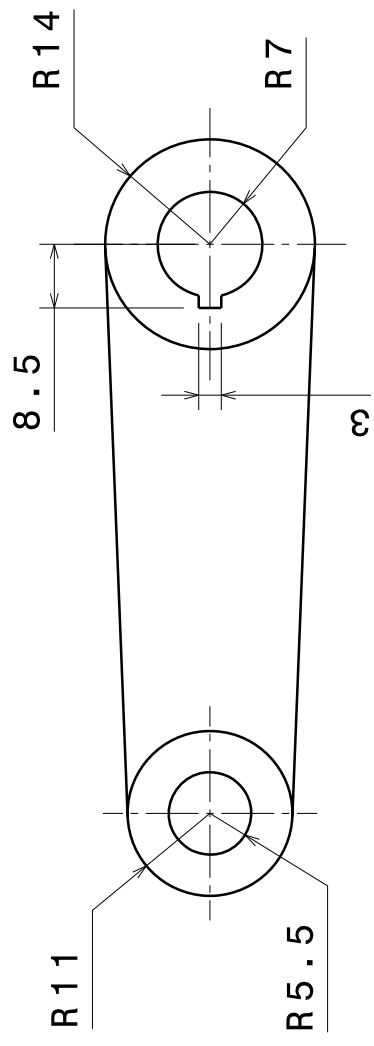

Projet

Vanne manuelle

Dessiné par

P. Morenton

Format

A4

Date

04/09/08

Revision

1.0

Bielle

Ecole Centrale Paris

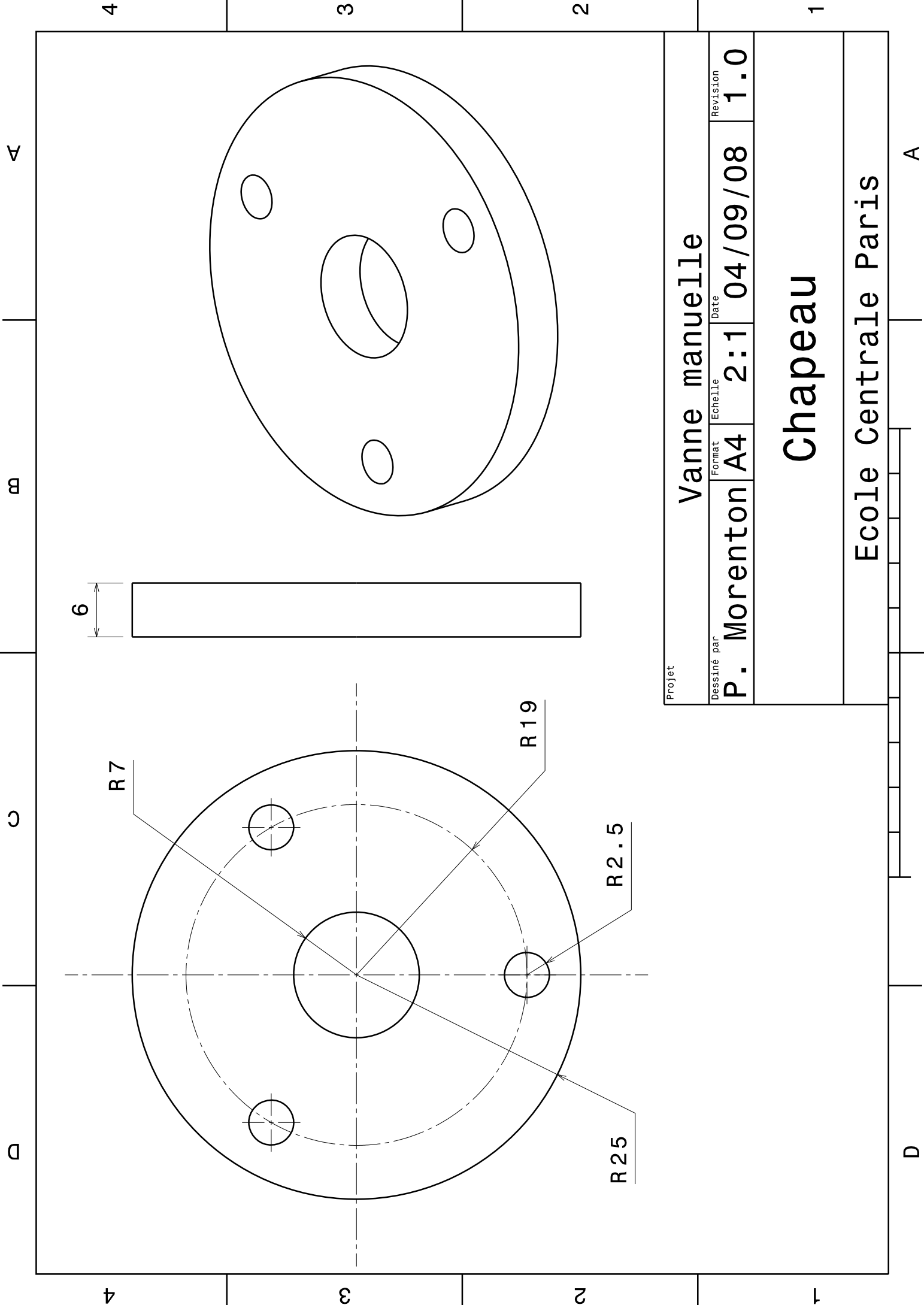

Projet

Vanne manuelle

Dessiné par

P. Morenton

Format

A4

Date

04/09/08

Revision

1.0

Chapeau

Ecole Centrale Paris

D

A

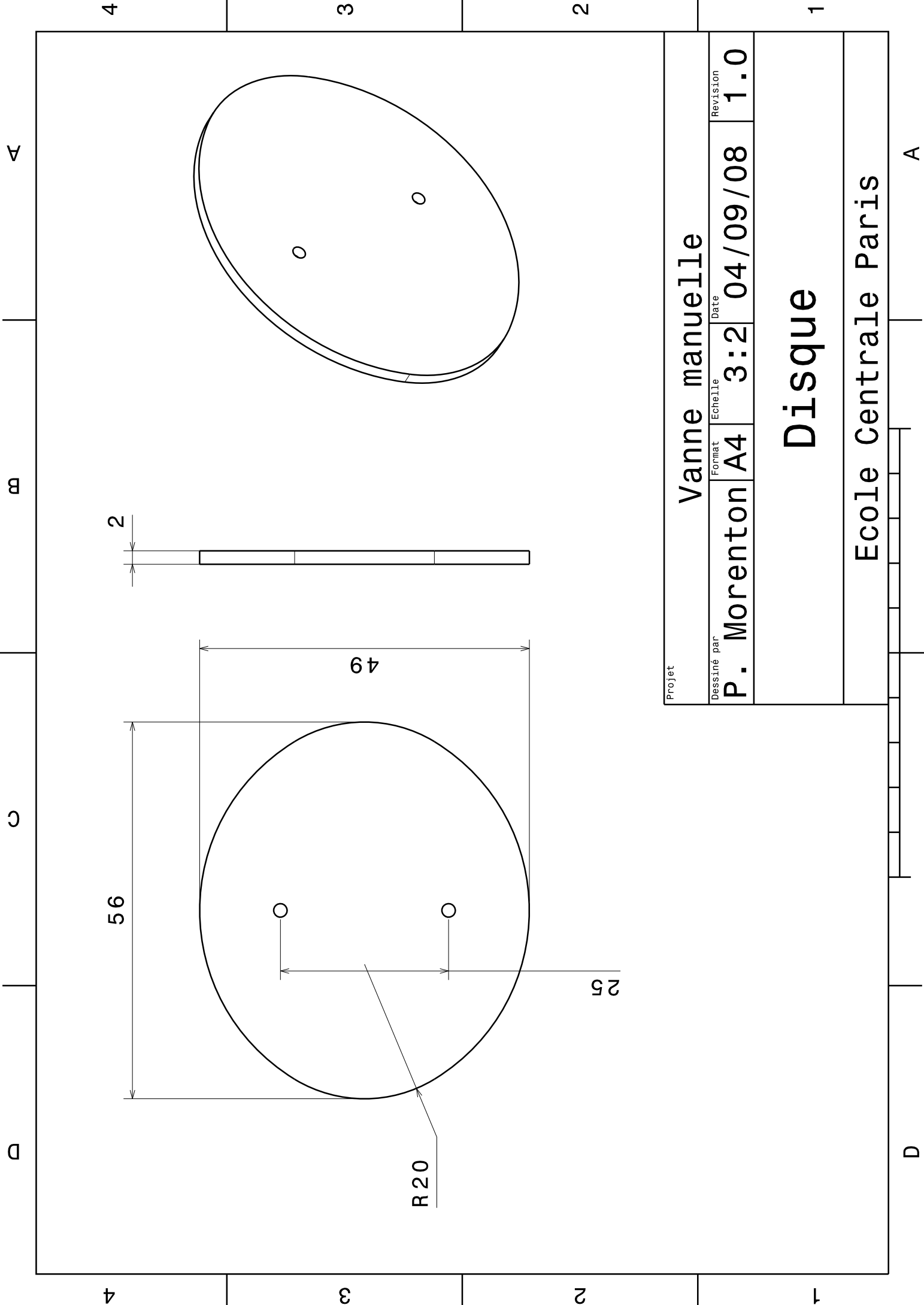

Projet

Vanne manuelle

Dessiné par

P. Morenton

Format

A4

Echelle

3:2

Date

04/09/08

Revision

1.0

Disque

Ecole Centrale Paris

D

A

4 3 2 1 A D C B

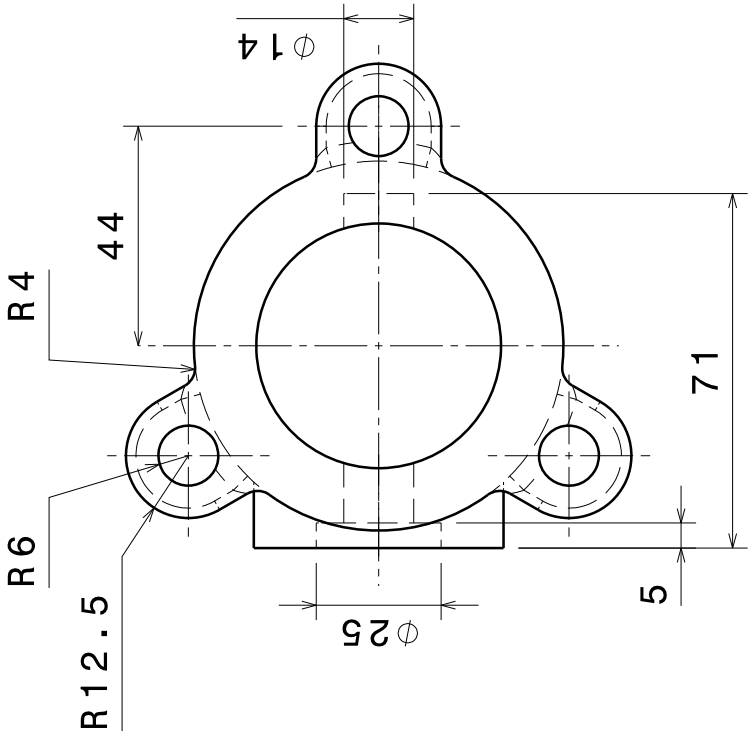
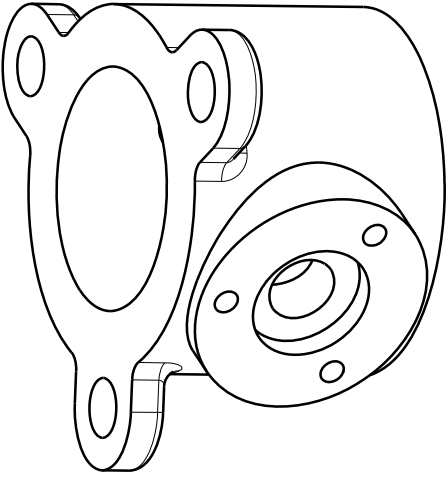
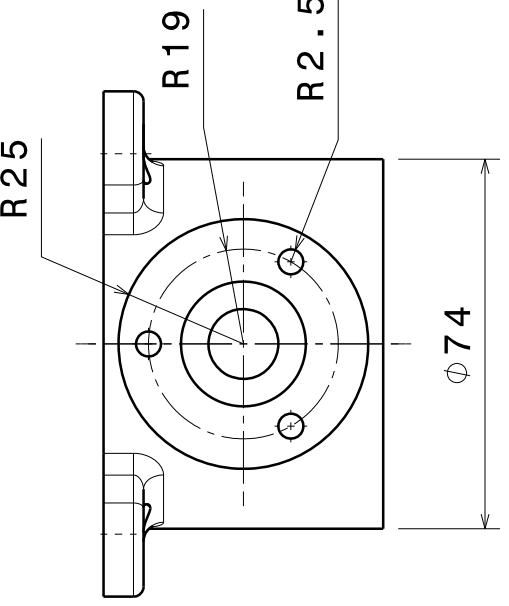
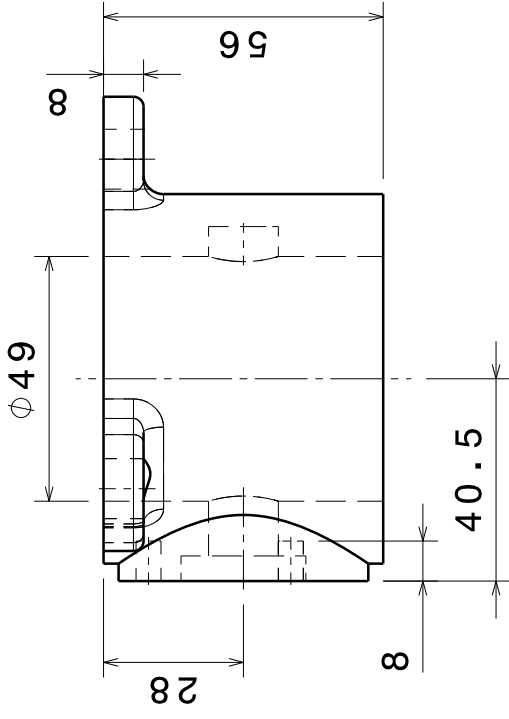

Projet

Vanne manuelle

Dessiné par

P. Morenton

Format

A4

Date

2:3

Revision

1.0

Corps

Ecole Centrale Paris

A

D